

CS & CS MAX AIR CURTAIN



INSTALLATION, OPERATION AND MAINTENANCE INSTRUCTIONS

English

(IMAGES ARE FOR ILLUSTRATION PURPOSES ONLY)

1 CONTENTS

	Page
1 CONTENTS	2
2 ELECTRICAL SAFETY	3
3 SPECIFICATIONS	3
4. INTRODUCTION	4
5. DELIVERY CONTENTS	5
6. TOOLS REQUIRED	6
7. INSTALLATION (HORIZONTAL UNITS)	6
8. INSTALLATION (VERTICAL UNITS)	8
9. ACCESS FOR ELECTRICAL CONNECTIONS	10
10. EXTERNAL CONTROLS	12
11. SYSTEM CONFIGURATION	12
12. COMMISSIONING THE SYSTEM	14
13. SIGN OFF	15
14. FAULT CONDITIONS	16
15. SERVICE & MAINTENANCE	16
16. WARRANTY	17
APPENDIX 1 — DIMENSIONS OF CS HORIZONTAL AIR CURTAIN	18
APPENDIX 2 — DIMENSIONS OF VERTICAL AIR CURTAIN	19
APPENDIX 3 — WIRING DIAGRAM CS AIR CURTAIN	20
APPENDIX 4 — WIRING DIAGRAM CS MASTER/SLAVE	21
APPENDIX 5 — WIRING DIAGRAM CS MAX AIR CURTAIN	22
APPENDIX 6 — WIRING DIAGRAM CS WITH MODBUS	23
APPENDIX 7 — WIRING DIAGRAM CS MAX WITH MODBUS	24
APPENDIX 8 — WIRING DIAGRAM CS MAX TO CONTROL BOX	25
17. DECLARATION OF CONFORMITY	26

2 ELECTRICAL SAFETY

Electrical Supply and Wiring to the Air Curtain

All electrical wiring and connections MUST be carried out by a competent qualified electrician in accordance with the latest edition of IEE wiring regulations and local statutory regulations if applicable.

- A 1 phase local isolator having a contact separation of at least 3mm on Live and Neutral poles must be fitted in the electrical supply to the air curtain and located in an accessible position adjacent to the unit.
- The appliance must be connected by cables having an appropriate heat resistant temperature rating.
- All supply cables, circuit breakers and other electrical installation equipment must be correctly sized for the air curtain model being installed; see section 3: Specifications.
- 20mm size cable glands or conduit connectors of IP44 rating or above must be used for the Electrical Supply and Control Cables into the air curtain.
- See Wiring Diagrams for connecting electrical supply and control cables to the air curtain. The air curtain must be earthed.

3 SPECIFICATIONS

Table 1

Air Curtain Model No	Electrical Supply (V/ph/Hz)	Rated Electrical Power Input (W)	Rated Current (A)	Max. Air Volume Flow rate (m ³ /h)	Specific Fan Power min. - max. (W/l/s)	Effective Width of Airstream (m)	Weight (kg)
CS/CS MAX 1000	230/1/50	172/430	0.79/1.8	1632/2250	0.09-0.38/ 0.20 - 0.70	1.10	60
CS/CS MAX 1500	230/1/50	253/630	1.1/2.7	2250/3400	0.08-0.40/ 0.23 - 0.69	1.63	70
CS/CS MAX 2000	230/1/50	334/820	1.38/3.5	2931/4500	0.08-0.41/ 0.25 - 0.68	2.15	85

Table 2

Air Curtain Model No	Electrical Supply (V/ph/Hz)	Rated Electrical Power Input (W)	Rated Current (A)	Max. Air Volume Flow rate (m ³ /h)	Specific Fan Power min. - max. (W/l/s)	Effective Width of Airstream (m)	Weight (kg)
CS/CS MAX 1000 V	230/1/50	172/430	0.79/1.8	1632/2250	0.09-0.38/ 0.20 - 0.70	1.10	62
CS/CS MAX 1500 V	230/1/50	253/630	1.1/2.7	2250/3400	0.08-0.40/ 0.23 - 0.69	1.63	72
CS/CS MAX 2000 V	230/1/50	334/820	1.38/3.5	2931/4500	0.08-0.41/ 0.25 - 0.68	2.15	87

4. INTRODUCTION

Established in the 1960s, Thermoscreens is a leading air curtain manufacturer that exports to over 60 countries worldwide.

As with all our products, the CS range air curtains are designed with energy efficiency in mind which is why they have fans with advanced EC motor technology to produce a very high air flow with low electrical energy consumption.

CS curtains are designed to be surface mounted inside a building and located horizontally or vertically besides the doorway.

This product is not designed to be used in applications where the door is continuously open and a large temperature difference exists over the opening (for example +20°C and -20°C). In these cases moisture can be entrained within the air stream and ice buildup will result.

They must not be installed on the outside of a building or built into a cabinet or recessed in any way.

Please complete the following details for your reference:

Date of Purchase
Place of Purchase
Serial Number

Proof of purchase is required to make a claim under warranty.



Thermoscreens Ltd
St. Mary's Road
Nuneaton
Warwickshire
England
CV11 5AU

Email: sales@thermoscreens.com — <http://www.thermoscreens.com>

Tel: +44 (0) 24 7638 4646 — Fax: +44 (0) 24 7638 8578

5. DELIVERY CONTENTS

The following items are supplied in the box at delivery.

NOTE: If any parts are missing or damaged contact your place of purchase.

CS/CS MAX Air Curtain

Note: End caps are supplied loose to be fitted during installation

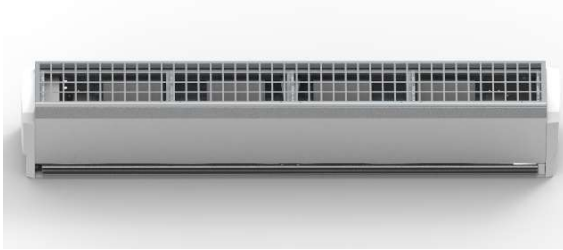

Ceiling Hanging Brackets (Horizontal Units Only)



M12 x 30mm bolts & M12 washers (x4) supplied

Door Switch (Optional)



Horizontal Unit Wall Hanging Brackets (Optional)



Wall Brackets and Fixing Bolts (Vertical Units Only)



6. TOOLS REQUIRED

The following tools are required for installation:

- Flat blade screwdrivers
- Pozi head screwdrivers
- 10mm and 19mm spanners
- Adjustable spanner
- Electric drill
- Equipment for working at height
- Appropriate lifting equipment
- Hacksaw

7. INSTALLATION (HORIZONTAL UNITS)

The air curtain is designed to be surface mounted inside a building and located horizontally over the doorway. It must not be installed outside of the building.

7.1 Location

Mount the air curtain above the doorway, with:

- the discharge grille not more than 4m above floor level
- at least 100mm clearance above the air curtain, see Fig 1
- with the back edge of the hanging bracket 100mm from the doorway, so the air curtain can swivel, see Fig 1, Figs 2a and 2b.

Beware of doorway top edges, structural beams, door opening/closure devices, etc., which may interfere with the air stream and affect the location of the unit.

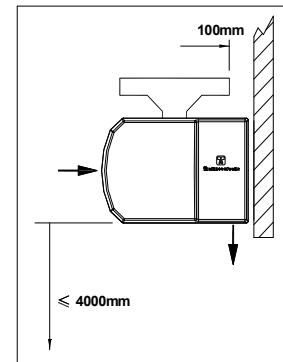

Fig 1

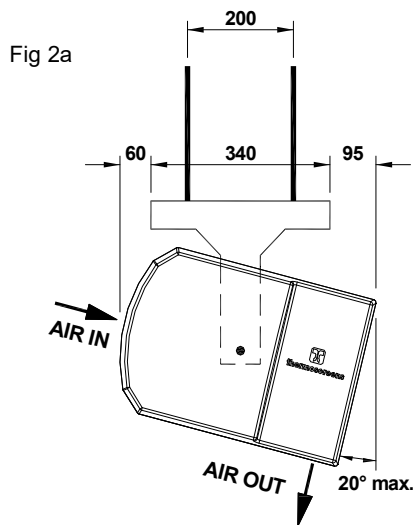

Fig 2a

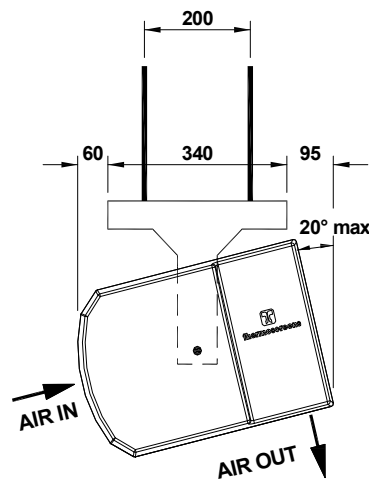

Fig 2b

NOTE: For the air curtain to work well the width of the open doorway should be less than the effective width of the airstream, see Table 1.

7.2 Ceiling Suspension

M10 Threaded rods (not supplied) are used to suspend the unit from the ceiling.

Suspend the unit from the ceiling as follows:

- Step 1** Locate Ceiling Hanging Brackets to each side of the air curtain as shown in Fig 3.
- Step 2** Fit two M12 bolts from inside the air curtain to secure each Ceiling Bracket. The top bolt is fitted through a slot which allows the air curtain to be tilted.
- Step 3** Fit and secure M10 threaded hanging rods into holes on the top face of each Ceiling Bracket.
- Step 4** Secure all hanging rods (x4) to a suitable structure that can support the weight of the unit (see section 3: Specifications for weights).
- Step 5** Tighten all fixing bolts until the air curtain is safely secured.



Fig 3



Fig 4

7.3 Wall Fixing

NOTE: Use suitable wall fixing bolts (not supplied) to fix the unit to the wall, taking into account the type of wall and the weight of the unit (see section 3: Specifications).

- Step 1** Drill fixing points in the wall, referring to Appendix 1 for correct positioning. Using suitable fixing bolts, fix both wall brackets to the wall.
- Step 2** Locate Ceiling Hanging Brackets to each side of the air curtain as shown in Fig 3.
- Step 3** Fit two M12 bolts from inside the air curtain to secure each Ceiling Bracket. The top bolt is fitted through a slot which allows the air curtain to be tilted.
- Step 4** Air curtain can be fitted directly to Ceiling Hanging Brackets using M10 nuts and bolts. Alternatively, using M10 threaded hanging rods air curtain can be fitted to Ceiling Brackets (see Appendix 1).
- Step 5** Tighten all fixing bolts until the air curtain is safely secured to the wall.

WARNING: It is the sole responsibility of the installer to ensure that the fixing locations and suspension system used are suitable for the air curtain being installed.

8. INSTALLATION (VERTICAL UNITS)

The CS air curtain is designed to be surface mounted inside a building and located vertically to the left or right hand side nearest the doorway. It must not be installed outside of the building.

8.1 Location

Mount the air curtain to the side of the doorway, with:

- the discharge grille not blocked by any obstacles within 1m of the unit
- at least 100mm clearance above the air curtain to allow for servicing
- at least 150mm clearance in front of the unit to allow for air to enter

Beware of doorway top edges, structural beams, door opening/closure devices, etc., which may interfere with the air stream and affect the location of the unit. For vertical units, provision should be made to protect the base of the unit from damage taking note of the above points.

For maximum effectiveness it is essential to ensure the top of the air curtain is slightly higher than the opening height of the door. Obstructions such as door opening devices, structural beams etc. will reduce the efficiency of the air curtain.

7.2 Floor Fixing

Before installing the air curtain obtain four suitable M10 fixing bolts, taking into account floor type and unit weight (see section 3: Specifications)*. Rawlplug[®] M10 Projecting Rawlbolt[®] 44356 type may be suitable. For dimensional details refer to the general assembly drawing, Appendix 2.

Determine and place the unit in position. A wall bracket is provided to secure the vertical air curtain to the wall and this must be used. So that the wall bracket touches the wall, ensure the back of the base plate touches against the wall, skirting board will need to be cut away if necessary.

Using the base plate as a template, mark the location of the four holes, see Fig 5.

Using a suitable masonry drill bit correctly drill the four marked out holes. Place M10 fixing bolts into each hole, ensuring all bolts are upright.



Fig 5

Reposition the air curtain base plate over the projecting bolts. Tighten each M10 nut as indicated in Fig 6. Ensure the vertical unit is secure, level and square. It may be necessary to pack under the base plate to ensure unit is vertical.



Fig 6

Using a hacksaw carefully cut the projecting bolt flush with the nut, ensuring the base plate is not damaged or marked in any way.



Fig 7

Remove only one M10 nut and refit and resecure bolt with a stainless steel M10 dome nut supplied. Repeat for each of the other three projecting bolts one at a time.



Fig 8

WARNING: It is the sole responsibility of the installer to ensure that the fixing locations and securing system used are suitable for the air curtain being installed.

9. ACCESS FOR ELECTRICAL CONNECTIONS

9.1 How to access terminals

To gain access to the air curtain for connection and commissioning, remove air inlet grilles and access panel as explained below.

First remove the plastic end caps at each end of the unit, if fitted, by pulling off to the side.

NOTE: All air curtain panels are protected in a plastic film. When access panels are removed this film can be removed.

9.1.1 Remove air inlet grilles

Using a Pozi No 1 screwdriver, remove the grille.

To remove, insert screwdriver into the hole at the bottom corner of the grille (see Fig 9) and turn the screw one quarter of a turn anticlockwise.

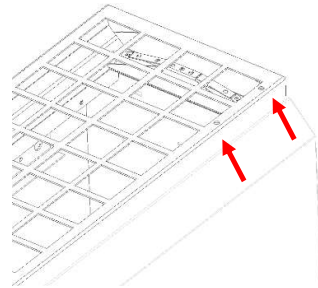

Fig 9

9.1.2 Remove bottom access panel and access terminals

Unfasten the securing screw at each end (see 1, Fig 10) and two screws in the centre (1500 and 2000 units).

To remove, slide the access panel (see 2, Fig 10) out forwards.

Remove the control box upper lid cover (see Fig 11 CS/MAX)

Connect electrical supply from local isolator.

Refer to Appendix 3 to 8 for Wiring Diagrams.

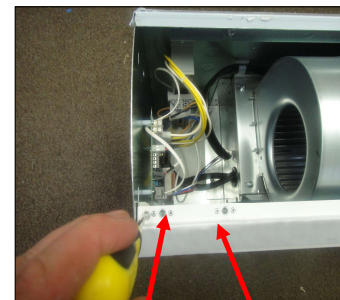

Fig 10



control box upper lid cover

Fig 11

9.2 Fan Speed Selection

Set a suitable fan speed by adjusting the EC speed potentiometer (see Fig 12 CS Fig. 13 CS MAX) to suit outdoor environmental conditions and indoor noise levels.

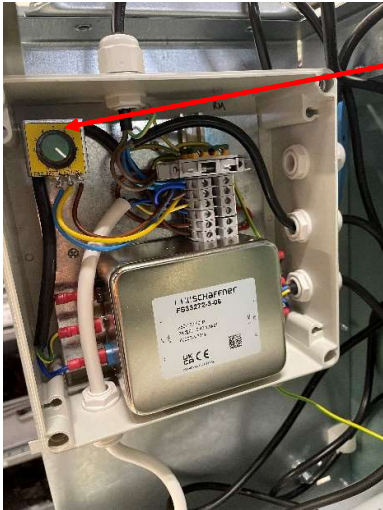

Fig 12

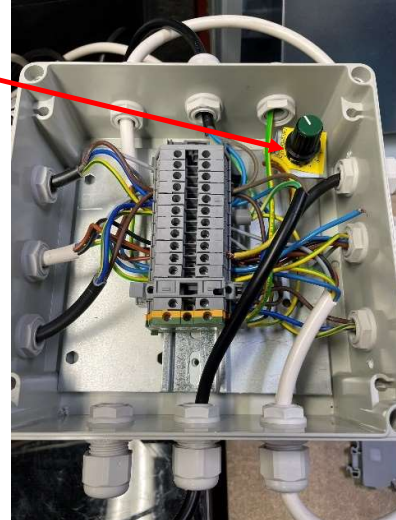

Fig 13

9.3 Mounting The Control Box (Modbus)

Mount the control box outside of the cold store in a dry location.



Remove 4-off screws for access to CCS PCB

Fixing brackets are provided on either side for ease of installation.

WARNING: It is the sole responsibility of the installer to ensure that the fixing locations and securing system used are suitable for the air curtain being installed.

Terminate the Modbus cable into the panel.

10. EXTERNAL CONTROLS

10.1 Remote switch contacts IN0, IN1

Terminals IN0 and IN1 on the CCS PCB inside the air curtain can be used to provide different control strategies using remote volt-free contacts (see Fig 14). This could be to provide remote On/Off from a timer or BMS Digital/Output contact, to work with a door switch or for simple weather compensation control to disable heating when outdoor air temperatures become warmer. Table 4 describes the different functions:

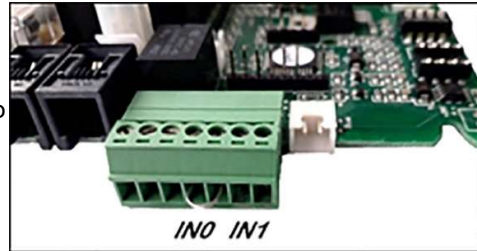





Fig14

Function	IN0		Notes
			
Remote On/Off (INHIBIT)	Unit operates normally in MANUAL Mode or AUTO Mode from the Remote Control	Unit switches off after 15s, with fan run-on at Medium fan speed if DIP 2 = OFF	On/Off is then done via IN0 using a remote volt-free contact.

Function	IN1		DIP 4	Notes
				
Door Switch Control	After 30s the heating is disabled and the fan goes to low speed	Unit operates normally in MANUAL Mode or AUTO Mode from the Remote Control	ON	Door Open:- Normal Control Door Closed:- Heating Off Low Fan Speed

11. SYSTEM CONFIGURATION

11.1 Remote switch contacts IN0, IN1

DIP switches on the air curtain CCS PCB (see Fig 15) provide the following optional features, as explained below:

- Disable fan run-on
- Thermostat master (for master/slave installations)
- Door switch control

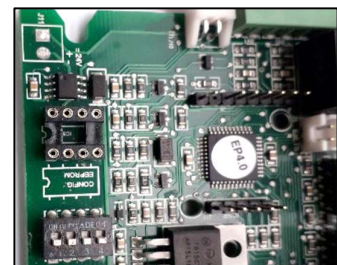
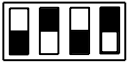

Fig 15

DIP setting	Notes
<p data-bbox="331 289 358 310">ON</p>  <p data-bbox="342 373 444 394">1 2 3 4</p>	<p data-bbox="493 241 787 296">Controller not required. i.e operates via Modbus.</p> <p data-bbox="493 325 824 352">Customer set to Dip 2 & 4 on.</p> <p data-bbox="493 384 613 441">EEPROM +25- 0 to 1</p>

NOTE: A range of advanced factory fitted and plug-in control options are available from Thermoscreens to enhance the performance of the CCS PCB inside the air curtain. These include advanced weather compensation control using a heating curve, outlet air temperature control, ECObus® BACnet/Modbus BMS control, modulating heater outputs and EEPROMs for non-standard control strategies. Visit the Thermoscreens website for details.

12. COMMISSIONING THE SYSTEM

12.1 Verify system operation

To commission the system, verify the following conditions are met:

- All fans are working.
- The door switch (if fitted) correctly starts the fans when the doors open.
- The timer off-delay relay keeps the fans running for the specified time (factory default is 24 seconds).
- Fan speed changes in accordance to the speed dial fixed within the unit (as shown in Fig 12 & 13).
- There is no excessive mechanical noise coming from the fans.

Table 3 gives an indication of the maximum air curtain mounting height versus fan speed setting. Please note, this is a rough guide only and the end user will need to assess the effectiveness of the air curtain by adjusting the angle of the unit and the fan speed to produce the best air stream to suit the particular situation.

Table 3

Fan Speed Setting	Maximum Unit Mounting Height For Horizontal Unit (m)	Maximum Door Width For Vertical Unit (m)
10.0	4.2	3.0*
9.5	4.0	3.0*
9.0	3.8	3.0*
8.5	3.6	3.0*
8.0	3.4	3.0*
7.5	3.2	3.0
7.0	3.0	3.0
6.5	2.8	2.8
6.0	2.6	2.6
5.5	2.4	2.4
5.0	2.2	2.2
4.5	2.0	2.0

* Unit is capped to 3m as typical warmer air will become entrained in the air stream and natural buoyancy will cause it to 'lift'.

12.2 Instruct customer and hand over

Before leaving site, hand over the installation to the customer/end user or their representative.

Explain that any person operating the air curtain must be given supervision and instruction by the person responsible for their safety, concerning the safe use of the unit and to understand any hazards involved. Children and those with reduced physical, sensory or mental capabilities should not operate the air curtain.

Recommend that the doorway should be closed whenever possible but that during times of high traffic it will become an 'open doorway'. The air curtain then serves an essential purpose of reducing the energy needed to maintain the internal temperatures.

Explain that the inlet grilles must be cleaned regularly and the unit serviced at schedule intervals – see section 12: Service & Maintenance.

NOTE: Leave these instructions with the customer/end user or their representative
--

13. SIGN OFF

Complete the following once commissioning is completed.

Installer signature:		Customer signature:	
Installer name:		Customer name:	
Installer company:		Customer company:	
Date:		Date:	

14. FAULT CONDITIONS

14.1 Fuses

In the event of an electrical fault check the fuses. The Control Box within the air curtain is fitted with a 5 x 20mm cartridge anti-surge 5A fuse. See Wiring Diagrams in Appendix 3 - 8.

The motors are also fitted with internal thermal overload protection that under normal operation shouldn't activate. If you find they have, refer to the Warranty section at the end of this set of instructions.

15. SERVICE & MAINTENANCE

WARNING: Failure to adequately maintain the unit and provide a suitable cleaning schedule will result in a loss of performance and reduced life expectancy of the air-curtain.

15.1 Every 6 months

WARNING: Before servicing, isolate and disconnect the air curtain from the electrical power.

WARNING: The following servicing and maintenance must be carried out by a competent electrician or a Thermoscreens appointed technician.

Clean and inspect the inside of the air curtain as follows:

- Step 1** Remove plastic end caps at each end of the unit by pulling off to the side.
- Step 2** Use a Pozi No.1 screwdriver to remove air inlet grilles by releasing the quarter-turn fasteners at the bottom corners of each air inlet grille.
- Step 3** Wipe clean to remove any build-up of dust and dirt within the air-curtain (inlet/outlet grilles, fan impellers, housings and motors).

NOTE: Build-up of dirt on fan impellers can cause vibration, noise and excessive wear on the motor bearings.

- Step 4** Check within the unit to ensure all electrical connections and crimped terminals are tight and that all cables are in good condition. Pay special attention to the edges of the electrical boxes to ensure they aren't damaged that would lead to water ingress.

Reconnect electrical supply and test to ensure correct operation (see Section 12: Commissioning).

16. WARRANTY

All units are covered by a two year warranty.

If any problems are encountered, please contact your installer/supplier.

Failing this please contact the Thermoscreens warranty department.

Care has been taken in compiling these instructions to ensure they are correct. Thermoscreens Ltd. disclaims all liability for damage resulting from any inaccuracies and/or deficiencies in this documentation. Thermoscreens Ltd. retain the right to change the specifications stated in these instructions.

Thermoscreens Ltd
St. Mary's Road Nuneaton
Warwickshire England
CV11 5AU

Email: sales@thermoscreens.com
Tel: + 44 (0) 24 7638 4646
Fax: + 44 (0) 24 7638 8578
www.thermoscreens.com

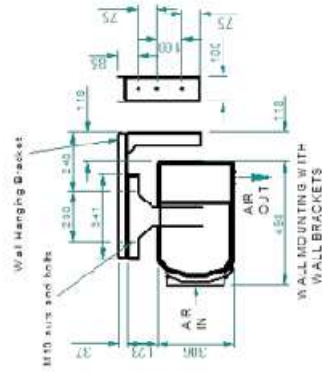
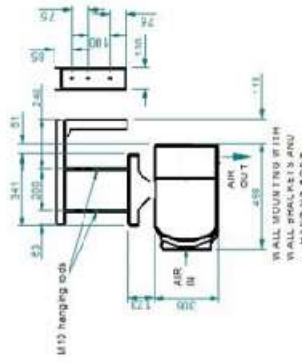
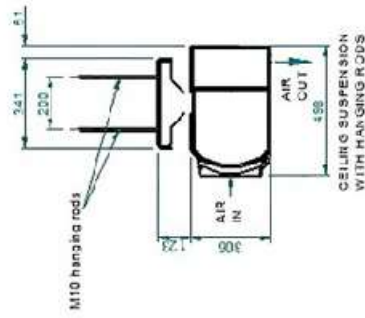
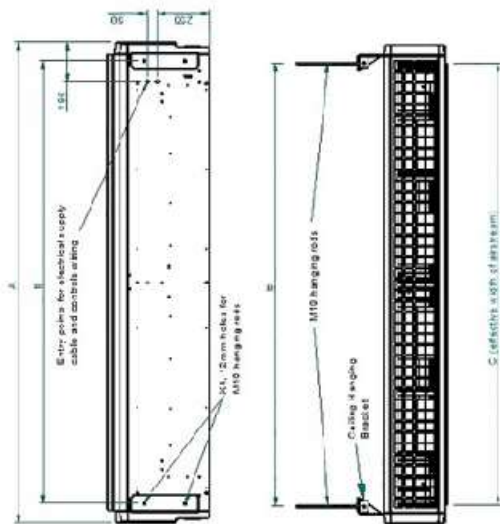

	CS/CS MAX 1000	CS/CS MAX 1500	CS/CS MAX 1830	CS/CS MAX 2000
A(mm)	1305	1830	2355	2355
B(mm)	1119	1644	1644	2169

APPENDIX 1 — DIMENSIONS OF CS HORIZONTAL AIR CURTAIN

WALL BRACKET

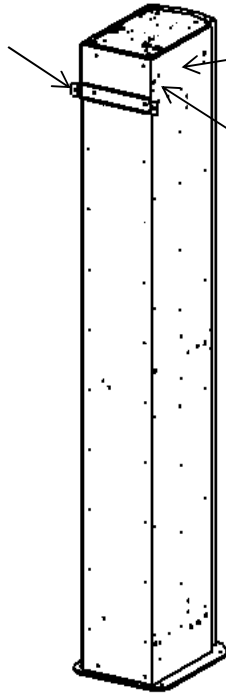

ELECTRICAL INLET FOR UNIT

CONTROL CONNECTION

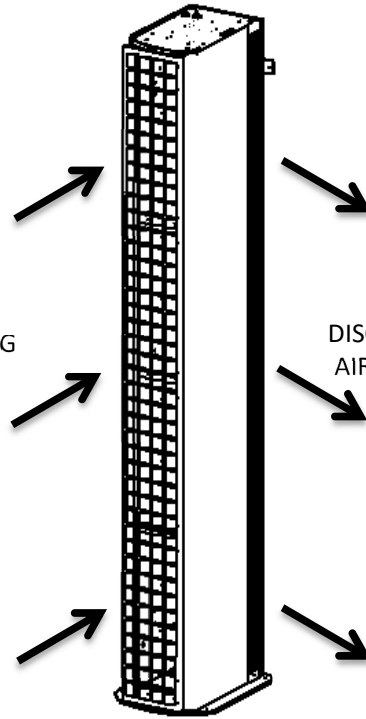

ENTERING AIR

DISCHARGE AIR

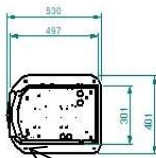

BOLT HOLES FOR M10 BOLTS – 4 OFF

Note. Left hand unit shown

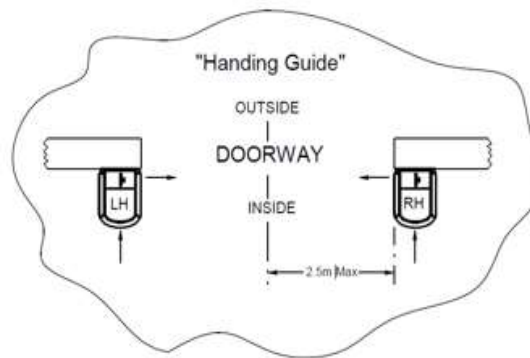
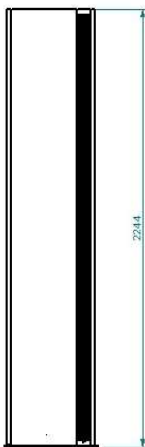

APPENDIX 2 — DIMENSIONS OF VERTICAL AIR CURTAIN

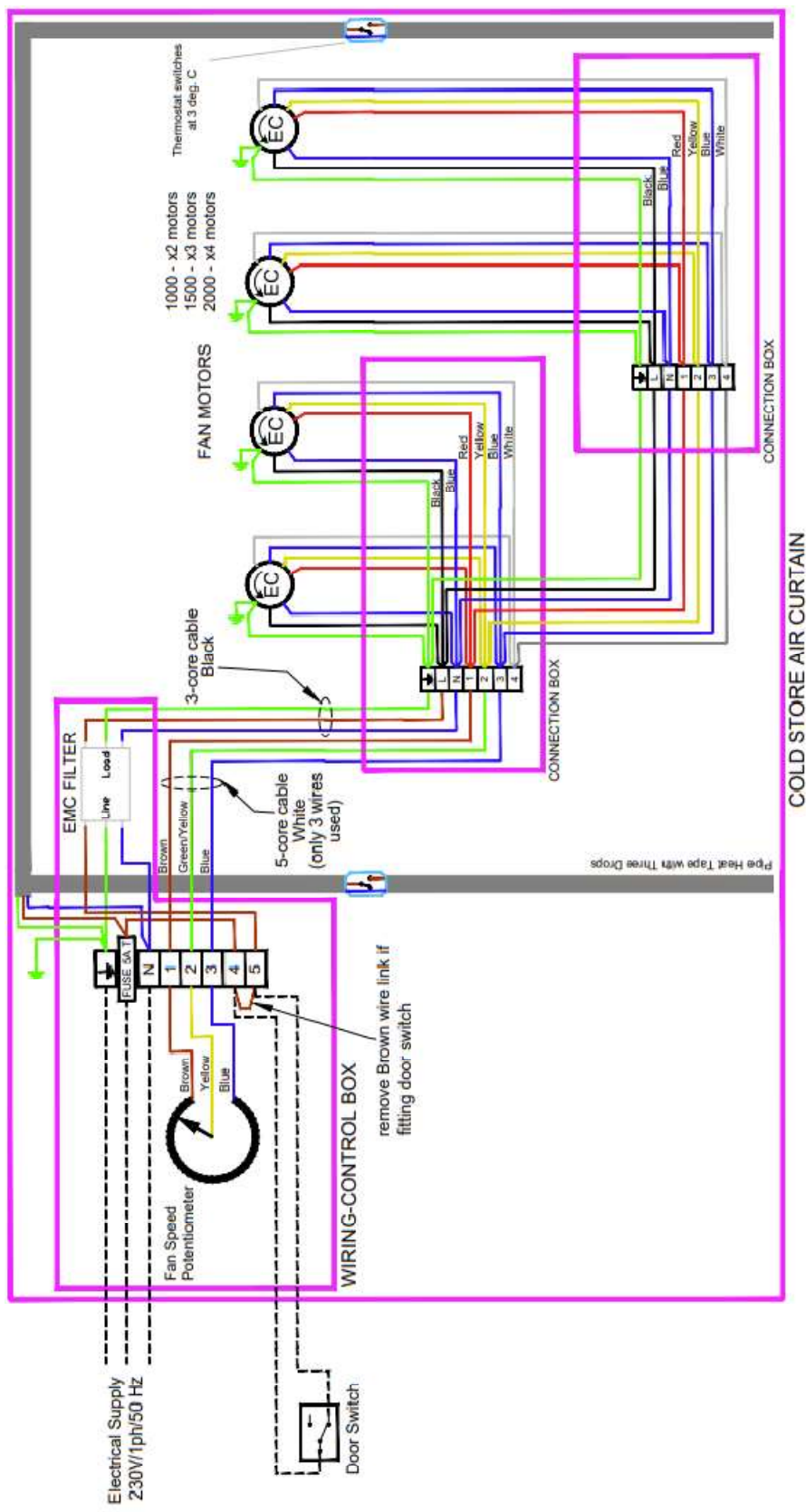

COLD STORE AIR CURTAIN

APPENDIX 3 — WIRING DIAGRAM CS AIR CURTAIN

Note: Example shown is for CS unit.

COLD STORE AIR CURTAIN - MASTER

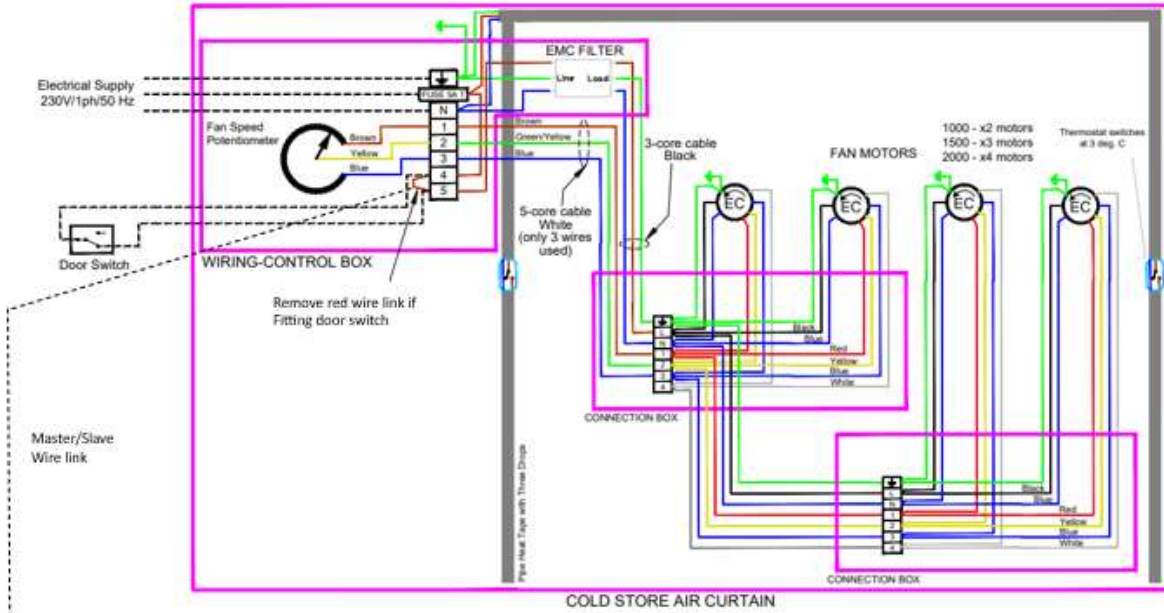

COLD STORE AIR CURTAIN - SLAVE

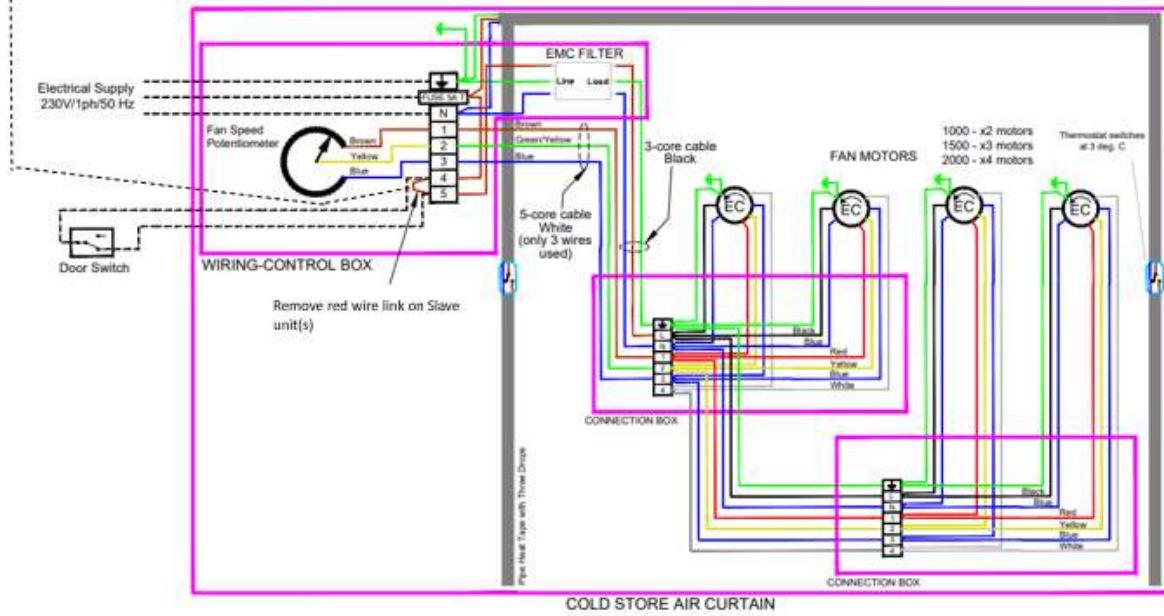

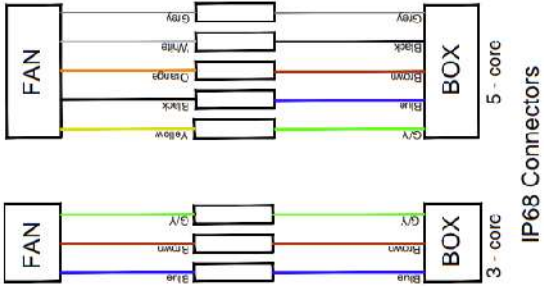
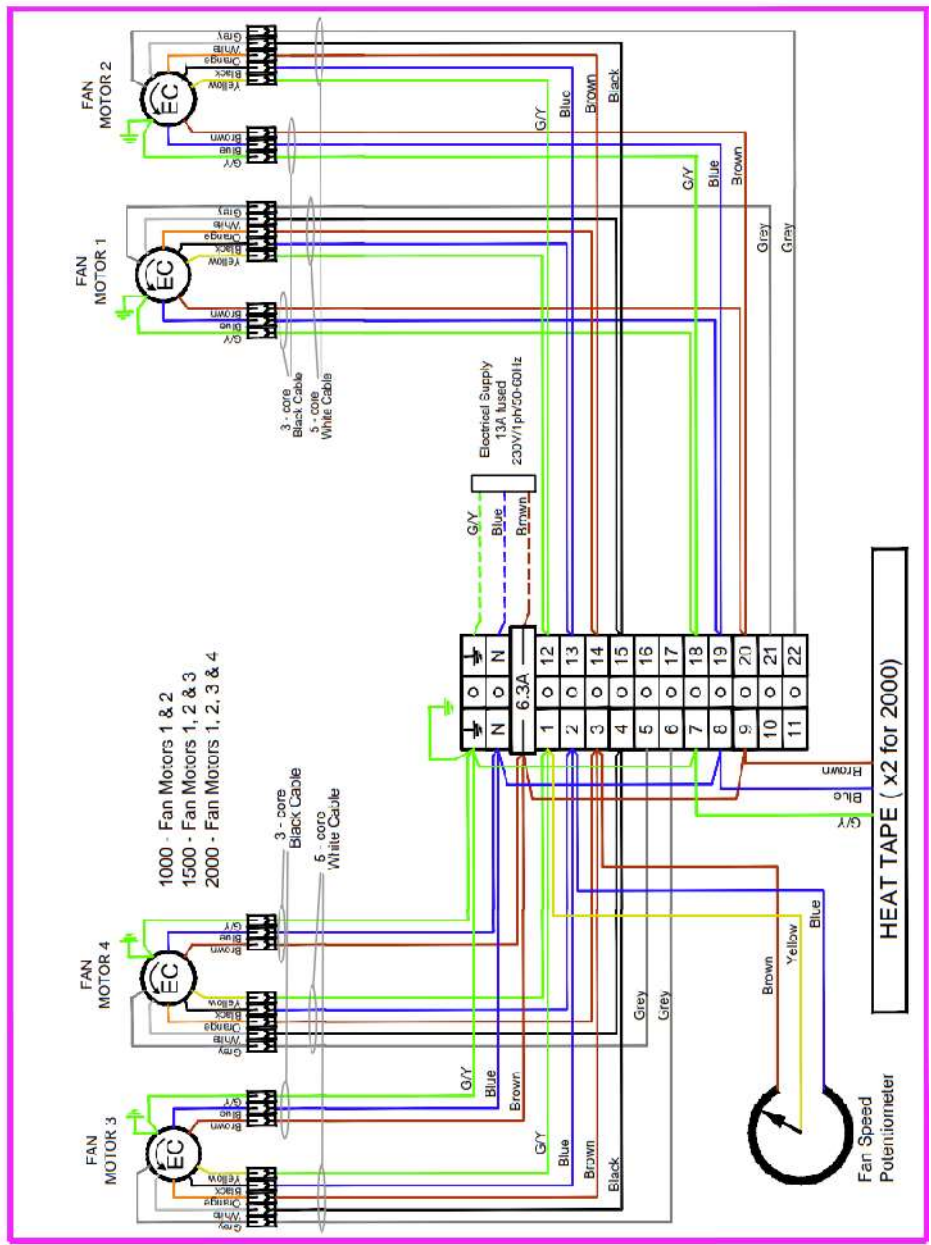

APPENDIX 5 — WIRING DIAGRAM CS MAX AIR CURTAIN

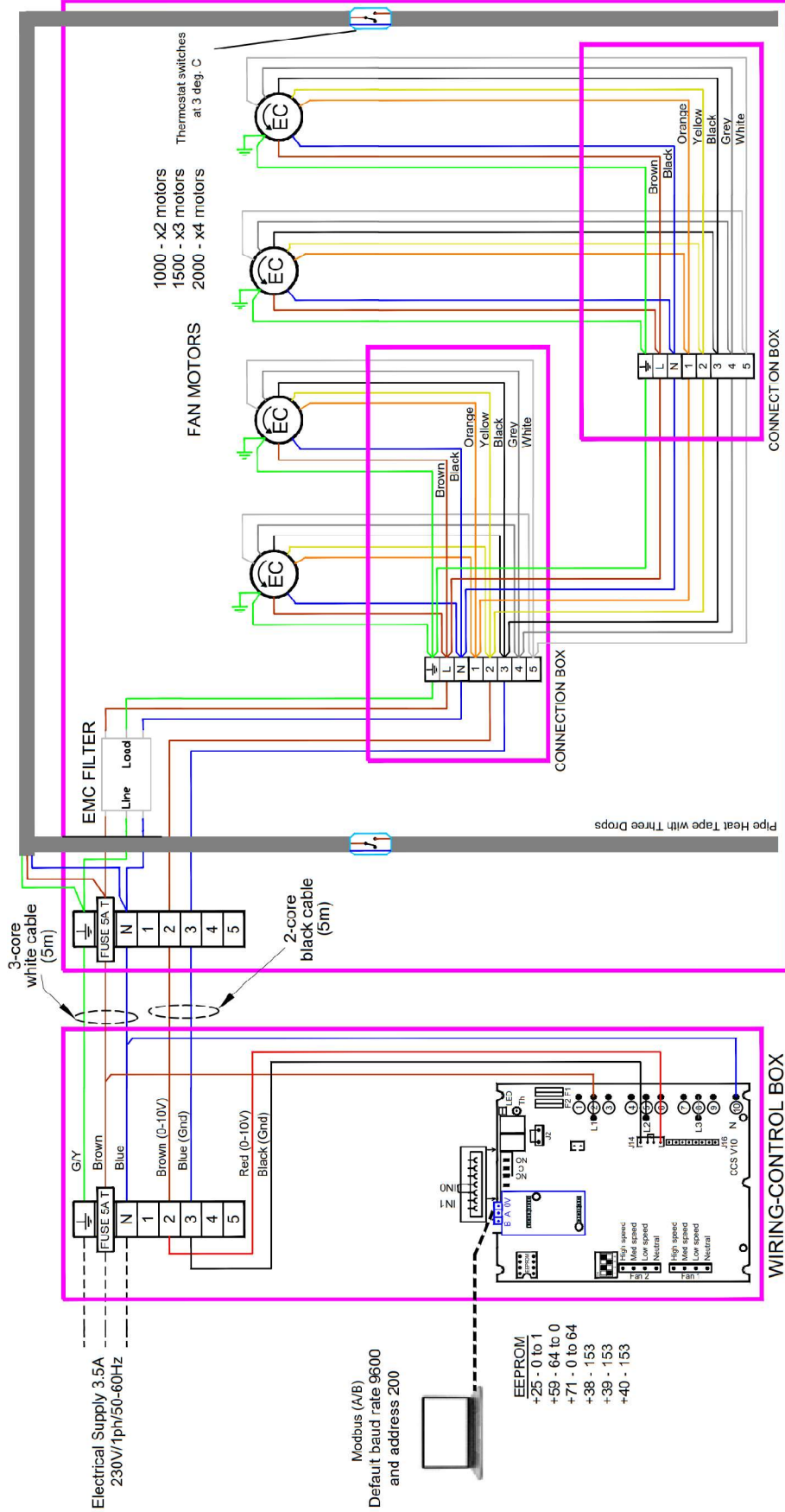

APPENDIX 6 — WIRING DIAGRAM CS WITH MODBUS

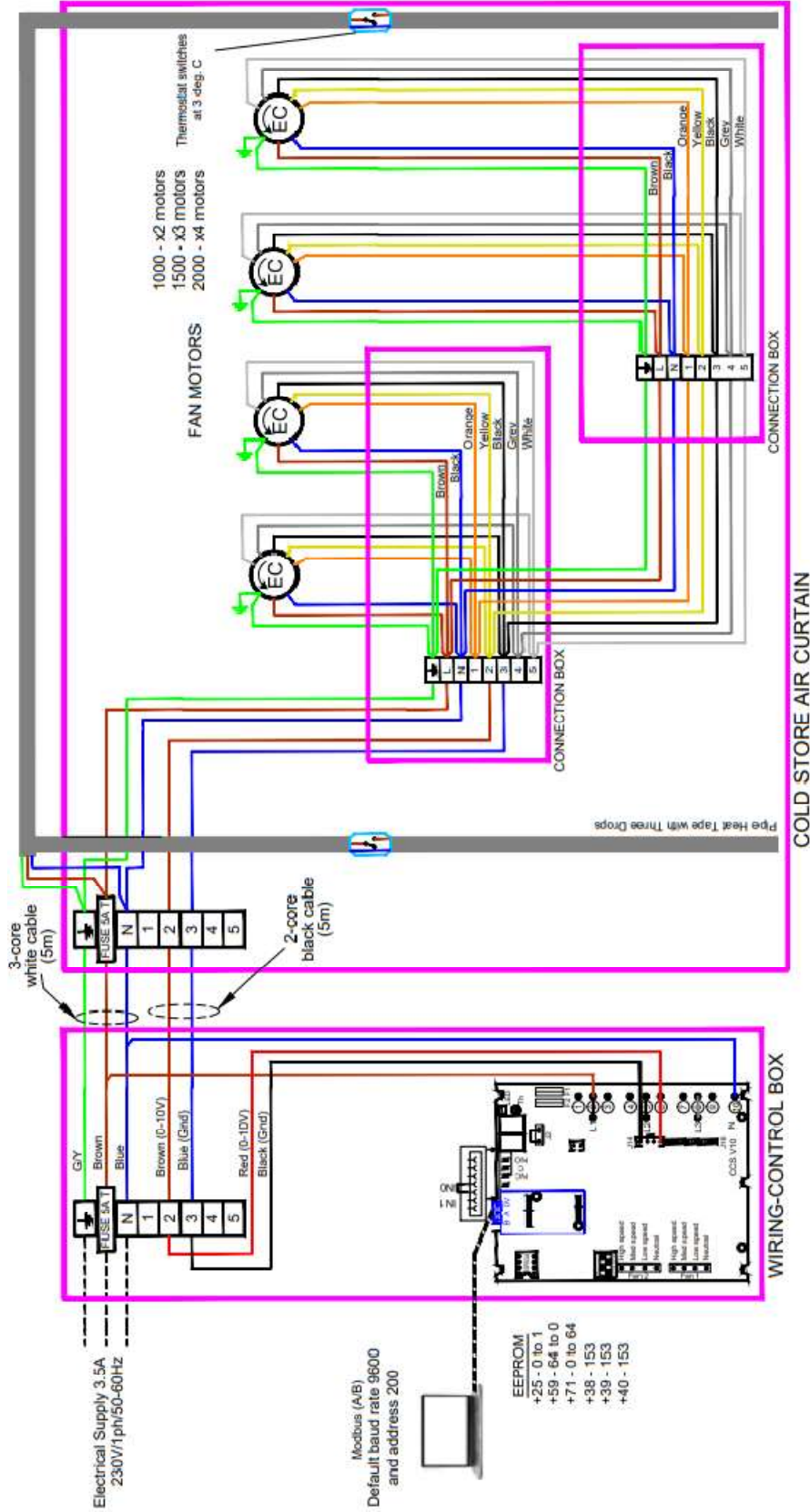

APPENDIX 7 — WIRING DIAGRAM CS MAX WITH MODBUS

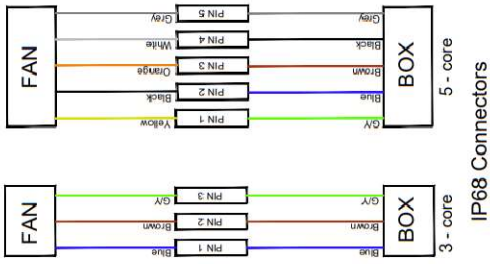
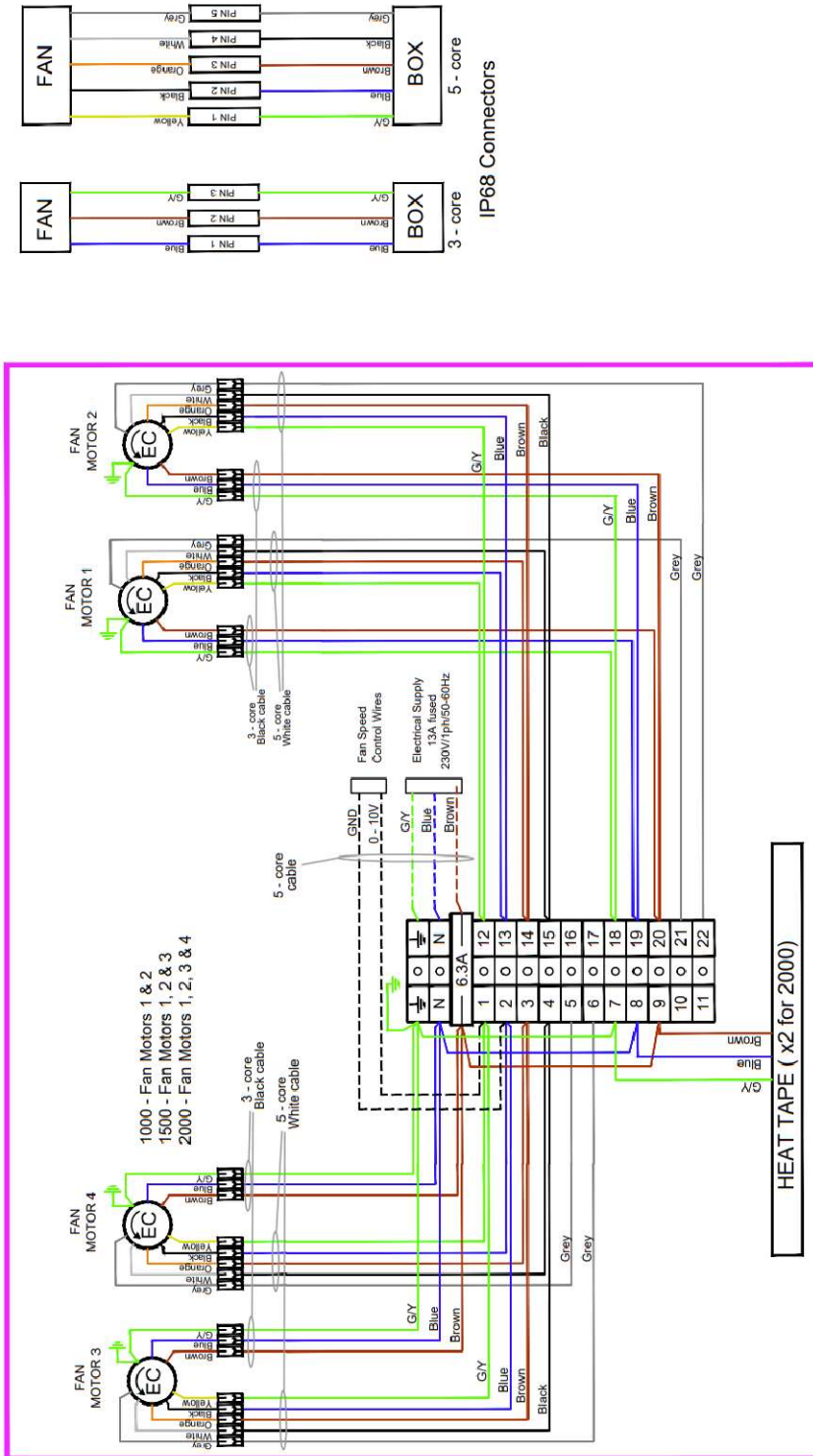

APPENDIX 8 — WIRING DIAGRAM CS MAX TO CONTROL BOX

17. DECLARATION OF CONFORMITY

Thermoscreens Ltd.
St. Mary's Road
Nuneaton
Warwickshire
CV11 5AU
United Kingdom
Telephone: +44 (0)24 7638 4646
www.thermoscreens.com



EC DECLARATION OF CONFORMITY
as defined by the EC Council Directive on Machinery 2006/42/EC,
the Low Voltage Directive 2014/35/EC, Electromagnetic Compatibility Directive 2014/30/EU
and the Energy related Products Directive 2009/125/EC

Herewith we declare that the air movement equipment designated below, on the basis of its design and construction in the form brought onto the market by us in accordance with the relevant safety, health and performance requirements of the Machinery. If alterations are made to the machinery without prior consultations with us, this declaration becomes invalid.

This declaration of conformity is issued under the sole responsibility of the manufacturer.

Designation of Equipment: AIR CURTAINS

Series Type: CS 1000; CS 1500; CS 2000;
Motor Type: EC

Relevant EC Council Directives: the Machinery Directive (2006/42/EC)
the Low Voltage Directive (2014/35/EU)
the Electromagnetic Compatibility Directive (2014/30/EU)
the Energy related Products Directive (2009/125/EC)

The object of the declaration described above is in conformity with the relevant Union harmonisation legislation:

Machinery	- BS EN ISO 12100:2010, BS EN ISO 13857:2008
LVD	- EN 60335-1:2012+A13:2017, EN 60335-2-30:2009+A11:2012
EMC	- EN 61000-6-1:2007, EN 61000-6-3:2007+A1:2011, EN 61000-3-2:2014+A2:2009, EN 61000-3-3:2013
ErP	- Commission Regulation (EU) No.327/2011, ISO 5801:2017, ISO 12759:2010

Basis of Self Attestation: Quality Assurance to BS EN ISO 9001:2015
B.S.I. Registered Firm Certificate Number FM 02234
SGS Test Report ELS150049/2/R/DC/11;
SGS Test Report EMC150049/1
CE Marking Association Test Report 6799 and 6800

Responsible Person: Mr. P.Humphries, Director, Thermoscreens Ltd.

Date: 1st April 2020

Signed:

A handwritten signature in black ink, appearing to read 'Paul Humphries', is written over a white background.