

HP DXE.

Heat pump air curtain

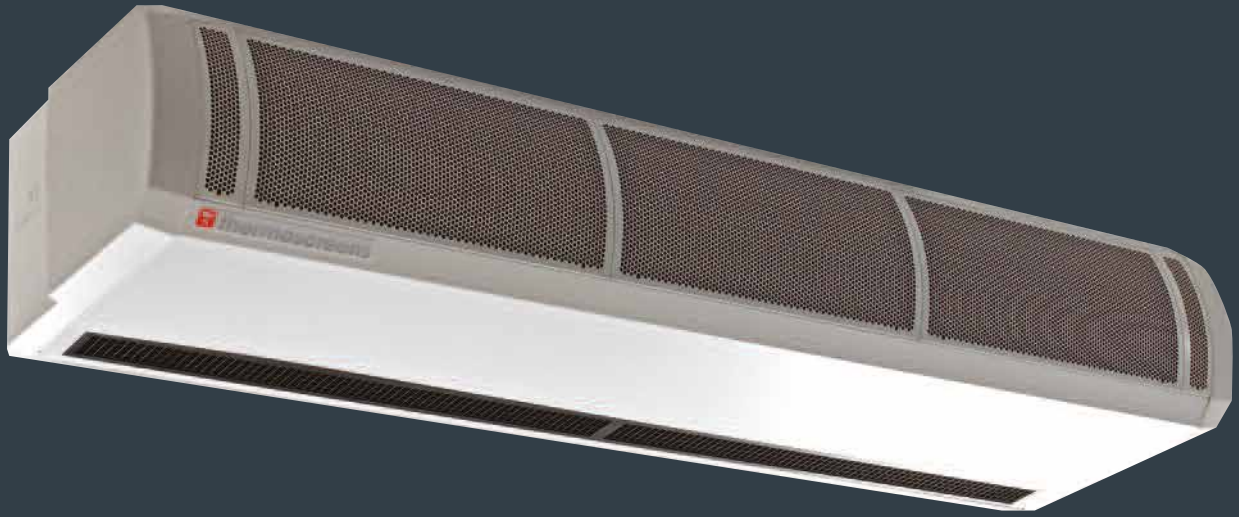

 **EcoPower.**TM

in cooperation with



Thermoscreens



Thermoscreens air curtains provide energy efficient solutions and comfort for retail, commercial, architectural and industrial applications. A comprehensive range of high-quality heated, ambient and cold store products is available, which can be surface mounted, recessed or installed vertically.

As a market leading manufacturer, Thermoscreens is actively responding to environmental issues. The need to reduce energy consumption and CO₂ emissions is being addressed through new innovations and revolutionary new air curtain solutions.

All products are designed with energy efficiency in mind, and with the introduction of Ecopower Air technology end users can now benefit from further energy savings and climate enhancing innovation.

Understanding its responsibility towards sustainability, Thermoscreens adheres strictly to the Environmental Management Systems BS EN ISO14001:2004.

Underpinning all of this is Thermoscreens' commitment to product quality, reliability, performance and delivery – evidenced by accreditation to the Quality Management Systems BS EN ISO9001:2008.



Known the world over, Mitsubishi is a trusted global leader associated with a variety of products and services. Founded in 1921, the company known today as Mitsubishi Electric, quickly rose to the forefront of the heating and cooling industry, a position they still enjoy today.

As a leading manufacturer of energy efficient heat pump systems, they constantly strive to meet and exceed the increasing demands placed on the industry. The drive to reduce energy consumption and the impact its use has on the environment is crucial and increasingly important to us all. Energy efficiency, has long driven Mitsubishi Electric to spend millions of pounds and huge amounts of resource on researching and developing the solutions of the future.

Responsible Manufacturing

Mitsubishi Electric boasts an explicit commitment to sustainable business practices such as energy and resource efficiency, minimising ecological impacts of their products and reducing greenhouse gas emissions. They are the only manufacturer in the industry recognised by Portfolio 21 as one of the top five companies in the world for their sustainable environmental policy. All of their factories are also ISO 14001 registered, the international standard that specifies a process for controlling and improving a company's environmental performance and with the advent of the Green Gateway Initiative, they strive to constantly promote best practice.

Ecopower Air technology increases the energy effectiveness and energy saving of the HP DXE Heat Pump air curtain. The new technology offers superior climate separation across a doorway by way of enhanced air stream projection and air stream uniformity.

Air velocity projection and air velocity uniformity are two of the most important attributes to describe the air stream discharging from an air curtain used to protect an opening.

Good air velocity projection means maintaining a high air velocity within the air stream at a long distance from the discharge nozzle of the air curtain. Good air velocity uniformity is having a consistent air velocity all along the whole length of the air curtain.

If the air velocity projection and air velocity uniformity of the air curtain is adequate, see Figure 1, it will reach right across and cover an opening, thereby, reducing the ingress of air and/or condition the air that may enter the opening.

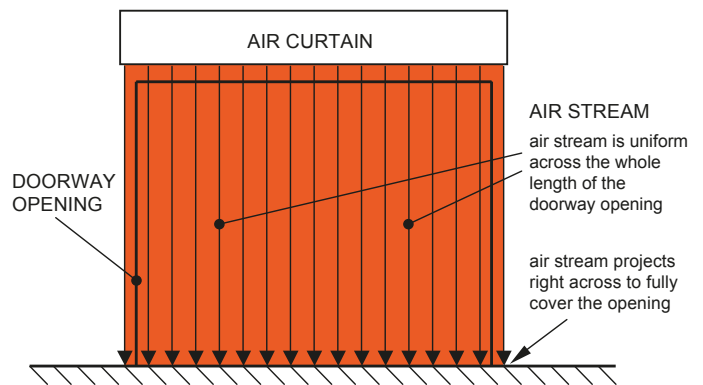

Figure 1

As shown in Figure 2, if the air velocity projection is inadequate the portion of the opening furthest from the air curtain is unprotected.

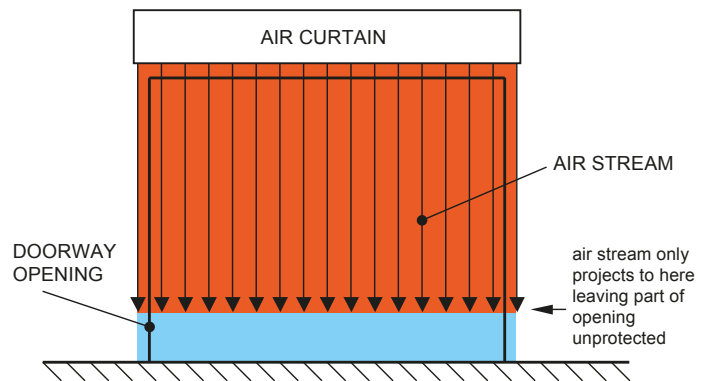

Figure 2

If the air velocity uniformity is poor some parts of the air stream will protect the opening whilst other parts will not, leaving some areas of the opening unprotected, see Figure 3.

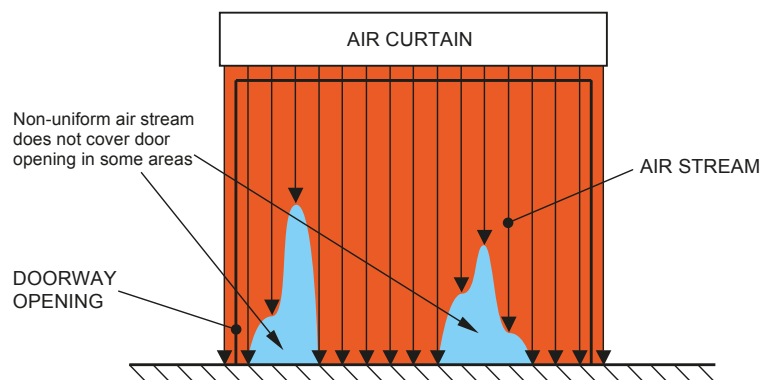
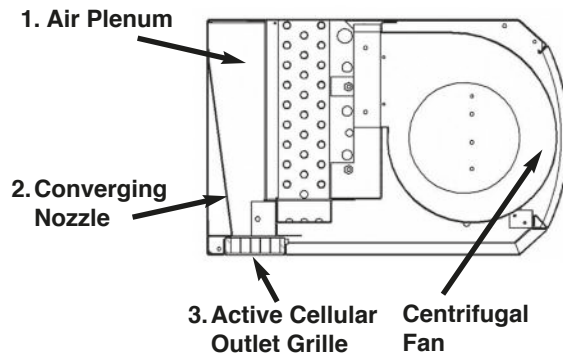

Figure 3

The new HP DXE Heat Pump air curtain is equipped with Ecopower Air technology which enhances the air velocity projection, air velocity uniformity and energy effectiveness. These enhancements are a direct result of the air plenum, converging nozzle and active cellular grille (Patent Pending).



1. Air Plenum:

is a pressure chamber into which the air first flows. Its presence and shape generates ‘Flow Static Pressure’ which results in the air being evenly distributed along the length and width of the air curtain discharge area thus eliminating low velocity zones or dead zones.

2. Converging Nozzle

The plenum transforms into a ‘Converging Nozzle’, (air shaft) creating the Venturi Effect. By moving the air from a larger to smaller enclosure, this creates higher air velocities which results in increased air stream projection. This increased air projection provides an enhanced air barrier.

3. Active Cellular Grille

The back pressure created by the cellular grille contributes to airflow uniformity. The cellular grille can be angled to achieve the desired directional airflow trajectory to suit the application, enhancing energy effectiveness. The air is guided through each cell of the active grille providing constant coverage.

Air velocity uniformity HP DXE NT

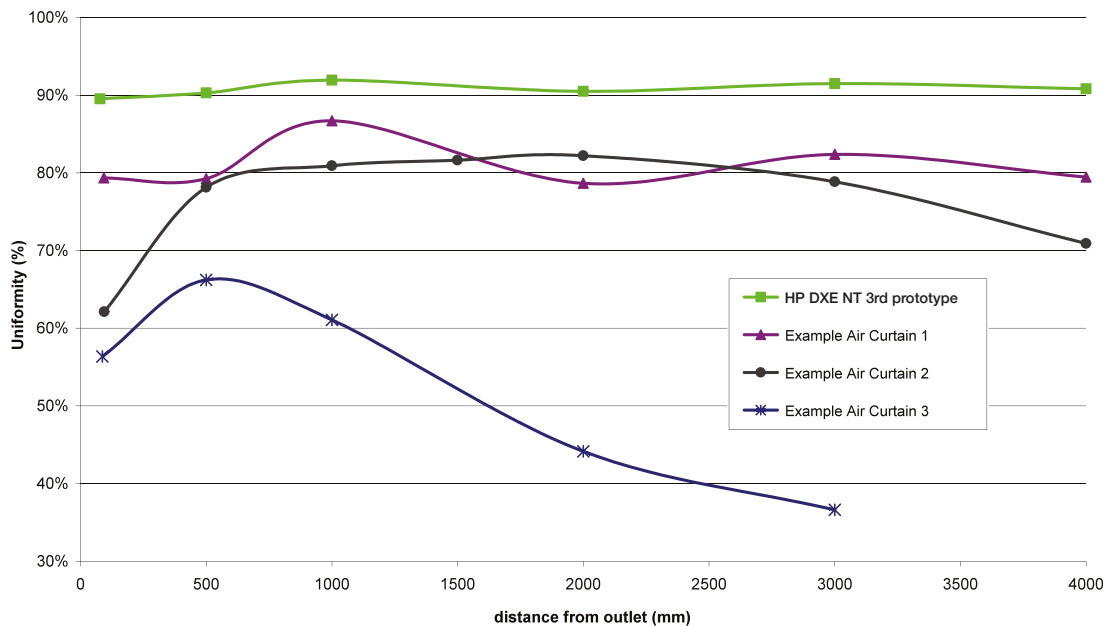

Graph derived from testing in accordance with newly released air curtain standard ISO 27327-1

BENEFITS OF ECOPOWER AIR

- **Efficient air barrier**
- **Superior air stream projection**
- **Superior air velocity uniformity**
- **Complete climate separation across doorway**
- **Reduced energy consumption**



- **Active cellular grille**
 - Creates back pressure
 - Cellular pockets concentrate air trajectory
- **Air velocity uniformity**
 - Eliminates 'dead' zones
- **Air velocity projection**
 - Maximum barrier effect

HP DXE - HEAT PUMP AIR CURTAIN



Main features:

- Available as surface mounted and recessed models
- Linear Expansion Valves (LEV) fitted inside City Multi units
- Plug and Play system for Mr Slim and City Multi units with all components mounted inside the casing
- Weather Compensation Energy Saving Control supplied with Mr Slim units
- Incorporates Ecopower Air technology
- Maximum mounting height 3.8m
- All units are supplied with an integral condensate drain tray to enable the air curtain to be used in cooling mode during warm weather
- Master/Slave on City Multi units
- Improved access for servicing and maintenance
- Defrost cycle auxiliary heater can be easily enabled during site commissioning (supplied disabled as standard)

ENERGY SAVING WEATHER COMPENSATION CONTROL

The HP DXE Mr Slim Heat Pump air curtain features the Mitsubishi Electric Weather Compensation Control (HEATING ECO). The controller achieves significant energy saving and carbon savings as the heat pump compressor automatically adjusts for energy requirement. The weather compensation control can reduce the payback period to less than 2 years.

The weather compensation control measures the outside air temperature by using an air sensor on the Mitsubishi Electric outdoor unit and automatically adjusts the temperature of the air curtain discharge air. It will select a warmer discharge air stream if it is cold outside and a cooler discharge air stream if it is not so cold outside, as the discharge air does not need to be as warm.

*If the outdoor temperature is 0°C, the discharge air temperature from the air curtain will be 40°C maximum. If the outdoor temperature is not cold the air curtain discharge air temperature is reduced. If the outdoor temperature is above 15°C, the air curtain discharge air is not heated and the compressor is off.

This means the heat pump system uses significantly less energy and the annual seasonal COP is higher than a normal heat pump air curtain.

Figure 1 shows a typical heating curve set up for weather compensation control, temperature points 1, 2, 3 and 4 are selected during commissioning.

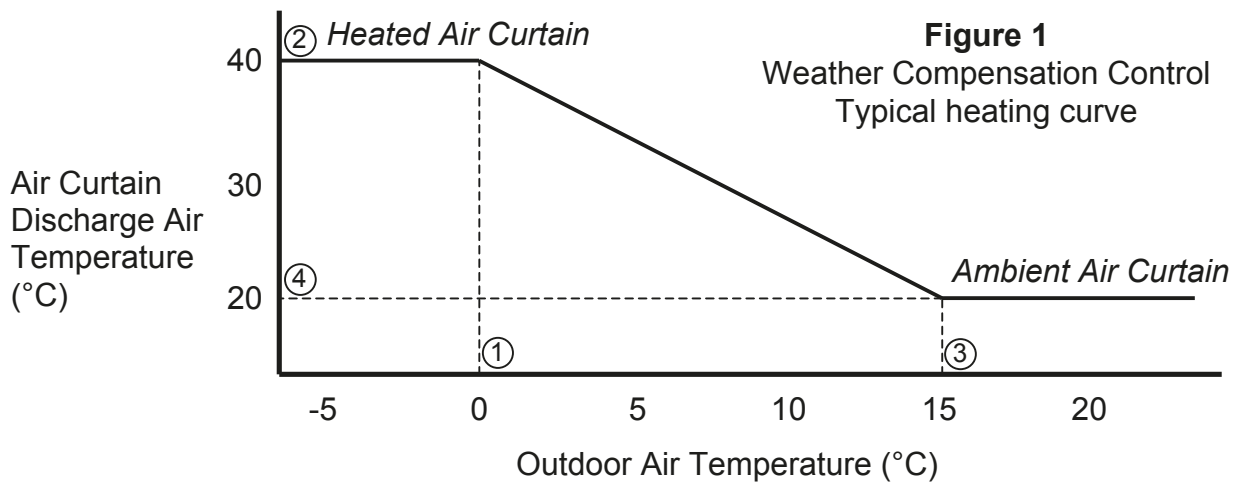

Footnote:

* ① Outdoor Air Temperature = 0°C, ② Discharge Air Temperature = 40°C

* ③ Outdoor Air Temperature = 15°C, ④ Discharge Air Temperature = 20°C (unheated)

TECHNICAL SPECIFICATIONS - MR SLIM



Mr Slim HP DXE Heat Pump Air Curtain - Surface Mounted

Model	Dimensions L x D x H (mm)	Effective Width of Airstream (m)	Electric Supply (50Hz)**	Max. DX Heat Out. (kW)+	Electrical Loading (A)	ISO 27327 Uniformity at outlet	Air Volume (m³/h)	Weight (kg)	Noise dB(A) @3m	Maximum Mounting Height (m)
HP1000 DXE	1300 x 468 x 306	1.10	230V~ 1P+N+E	8.3 with P71 unit	0.8 or (7.3)*	90%	Hi - 1310 Me - 1170 Lo - 970	46	Hi - 58 Me - 55 Lo - 50	3.8
HP1500 DXE	1825 x 468 x 306	1.63	230V~ 1P+N+E	13.8 with P125 unit	1.2 or (12.1)*	92%	Hi - 2070 Me - 1800 Lo - 1450	67	Hi - 58 Me - 54 Lo - 49	3.8
HP2000 DXE	2350 x 468 x 306	2.15	230V~ 1P+N+E	15.9 with P140 unit	1.4 or (14.4)*	90%	Hi - 2590 Me - 2340 Lo - 1930	84	Hi - 58 Me - 55 Lo - 50	3.8
HP2000 DXE	2350 x 468 x 306	2.15	230V~ 1P+N+E	21.0 with P200 unit	1.4 or (14.4)*	90%	Hi - 2590 Me - 2340 Lo - 1930	84	Hi - 58 Me - 55 Lo - 50	3.8

For use with a Mitsubishi Electric R410A Mr Slim Heat Pump System.

+Maximum DX Heating Output at 7/6°C outdoor condition, 20°C indoor temp.

* (Amps per phase) for a 400V~3P+N+E local electrical supply if defrost auxiliary heater is enabled during commissioning -

**then need a 400V~3P+N+E local electrical supply for the unit instead of the 230V~1P+N+E electrical supply.



Mr Slim HP R DXE Heat Pump Air Curtain - Recessed

Model	Dimensions L x D x H (mm)	Effective Width of Airstream (m)	Electric Supply (50Hz)**	Max. DX Heat Out. (kW)+	Electrical Loading (A)	ISO 27327 Uniformity at outlet	Air Volume (m³/h)	Weight (kg)	Noise dB(A) @3m	Maximum Mounting Height (m)
HP1000R DXE	1250 x 485 x 354	1.18	230V~ 1P+N+E	8.3 with P71 unit	0.8 or (7.3)*	90%	Hi - 1310 Me - 1170 Lo - 970	52	Hi - 58 Me - 55 Lo - 50	3.8
HP1500R DXE	1750 x 485 x 354	1.68	230V~ 1P+N+E	13.8 with P125 unit	1.2 or (12.1)*	92%	Hi - 2070 Me - 1800 Lo - 1450	75	Hi - 58 Me - 54 Lo - 49	3.8
HP2000R DXE	2340 x 485 x 354	2.27	230V~ 1P+N+E	15.9 with P140 unit	1.4 or (14.4)*	90%	Hi - 2590 Me - 2340 Lo - 1930	93	Hi - 58 Me - 55 Lo - 50	3.8
HP2000R DXE	2340 x 485 x 354	2.27	230V~ 1P+N+E	21.0 with P200 unit	1.4 or (14.4)*	90%	Hi - 2590 Me - 2340 Lo - 1930	93	Hi - 58 Me - 55 Lo - 50	3.8

For use with a Mitsubishi Electric R410A Mr Slim Heat Pump System.

+Maximum DX Heating Output at 7/6°C outdoor condition, 20°C indoor temp.

* (Amps per phase) for a 400V~3P+N+E local electrical supply if defrost auxiliary heater is enabled during commissioning -

**then need a 400V~3P+N+E local electrical supply for the unit instead of the 230V~1P+N+E electrical supply.

TECHNICAL SPECIFICATIONS - CITY MULTI



City Multi HP DXE Heat Pump Air Curtain - Surface Mounted

Model	Dimensions L x D x H (mm)	Effective Width of Airstream (m)	Electric Supply (50Hz)**	Max. DX Heat Out. (kW)+	Electrical Loading (A)	ISO 27327 Uniformity at outlet	Air Volume (m³/h)	Weight (kg)	Noise dB(A) @3m	Maximum Mounting Height (m)
VRF HP1000 DXE	1300 x 468 x 306	1.10	230V~ 1P+N+E	8.3 P71 index	0.8 or (7.3)*	90%	Hi - 1310 Me - 1170 Lo - 970	46	Hi - 58 Me - 55 Lo - 50	3.8
VRF HP1500 DXE	1825 x 468 x 306	1.63	230V~ 1P+N+E	13.2 P125 index	1.2 or (12.1)*	92%	Hi - 2070 Me - 1800 Lo - 1450	67	Hi - 58 Me - 54 Lo - 49	3.8
VRF HP2000 DXE	2350 x 468 x 306	2.15	230V~ 1P+N+E	15.7 P140 index	1.4 or (14.4)*	90%	Hi - 2590 Me - 2340 Lo - 1930	84	Hi - 58 Me - 55 Lo - 50	3.8

For use with a Mitsubishi Electric R410A City Multi system.

+Maximum DX Heating Output at 7/6°C outdoor condition, 20°C indoor temp.

*(Amps per phase) for a 400V~3P+N+E local electrical supply if defrost auxiliary heater is enabled during commissioning -

**then need a 400V~3P+N+E local electrical supply for the unit instead of the 230V~1P+N+E electrical supply.



City Multi HP DXE Heat Pump Air Curtain - Recessed

Model	Dimensions L x D x H (mm)	Effective Width of Airstream (m)	Electric Supply (50Hz)**	Max. DX Heat Out. (kW)+	Electrical Loading (A)	ISO 27327 Uniformity at outlet	Air Volume (m³/h)	Weight (kg)	Noise dB(A) @3m	Maximum Mounting Height (m)
VRF HP1000R DXE	1250 x 485 x 354	1.18	230V~ 1P+N+E	8.3 P71 index	0.8 or (7.3)*	90%	Hi - 1310 Me - 1170 Lo - 970	52	Hi - 58 Me - 55 Lo - 50	3.8
VRF HP1500R DXE	1750 x 485 x 354	1.68	230V~ 1P+N+E	13.2 P125 index	1.2 or (12.1)*	92%	Hi - 2070 Me - 1800 Lo - 1450	75	Hi - 58 Me - 54 Lo - 49	3.8
VRF HP2000R DXE	2340 x 485 x 354	2.27	230V~ 1P+N+E	15.7 P140 index	1.4 or (14.4)*	90%	Hi - 2590 Me - 2340 Lo - 1930	93	Hi - 58 Me - 55 Lo - 50	3.8

For use with a Mitsubishi Electric R410A City Multi system.

+Maximum DX Heating Output at 7/6°C outdoor condition, 20°C indoor temp.

*(Amps per phase) for a 400V~3P+N+E local electrical supply if defrost auxiliary heater is enabled during commissioning -

**then need a 400V~3P+N+E local electrical supply for the unit instead of the 230V~1P+N+E electrical supply.

GA DRAWINGS - MR SLIM HP DXE

Surface Mounted

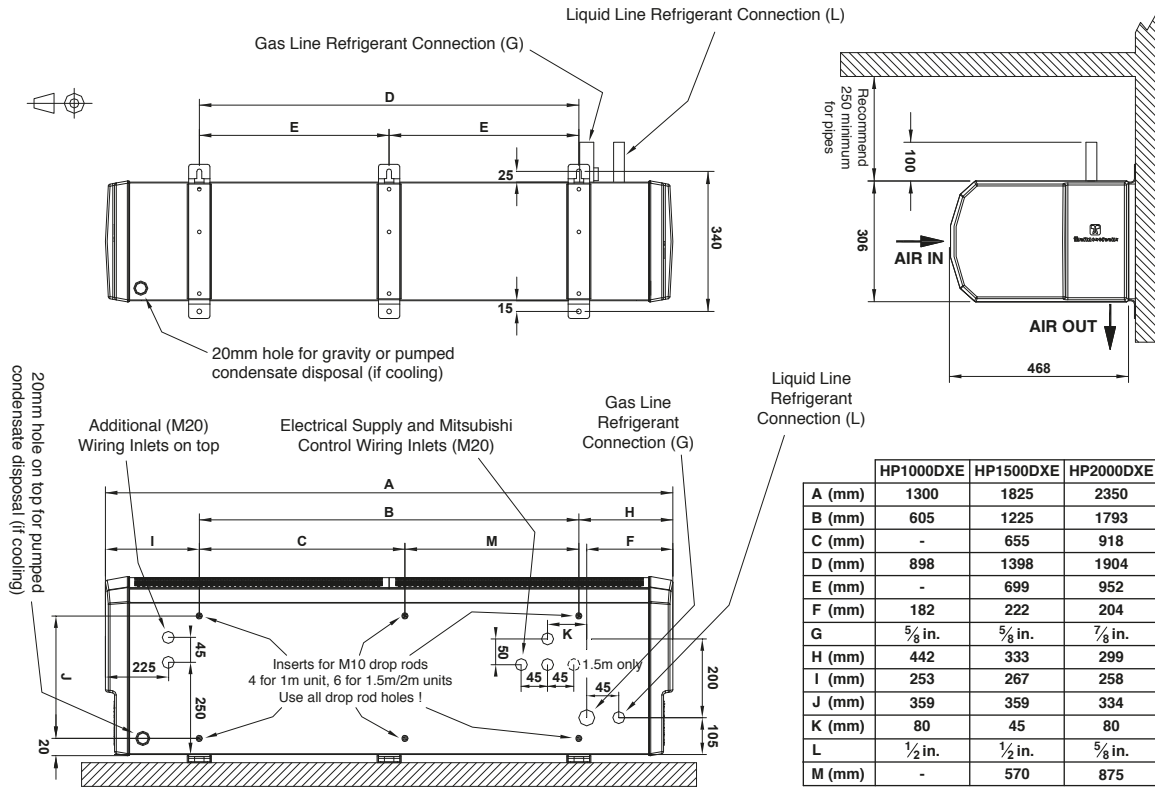

Recessed

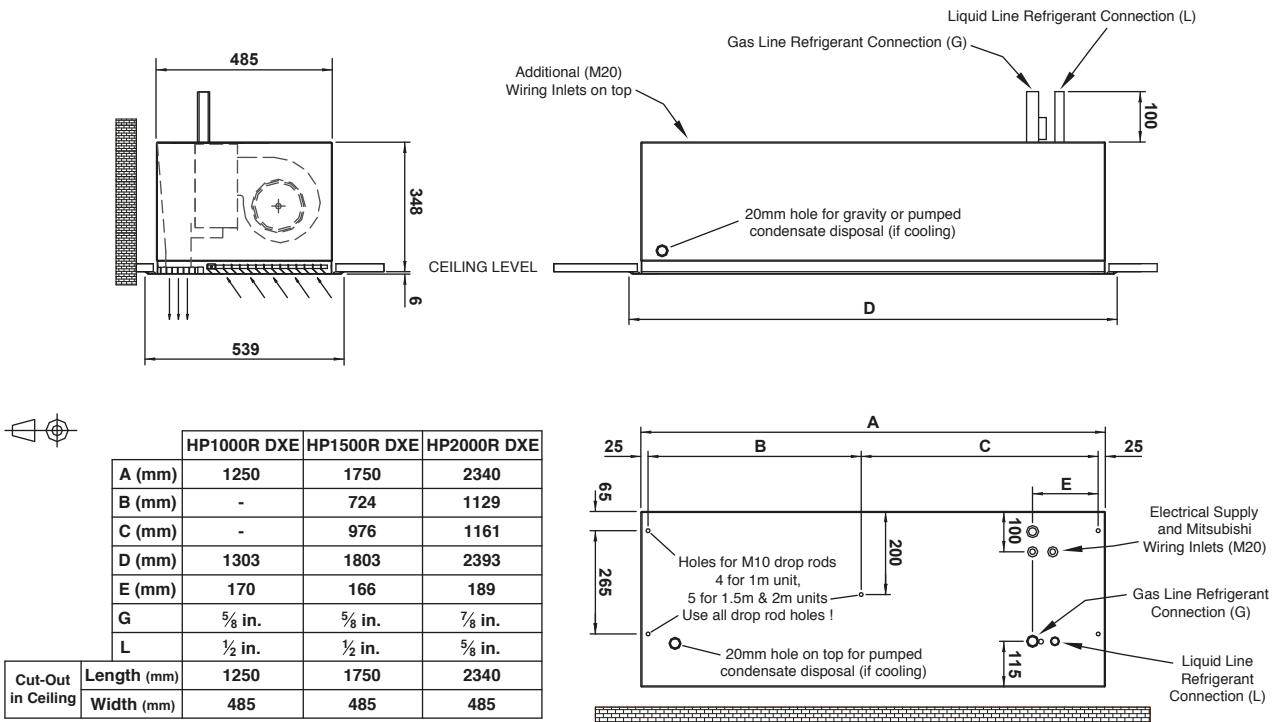

GA DRAWINGS - CITY MULTI HP DXE

Surface Mounted

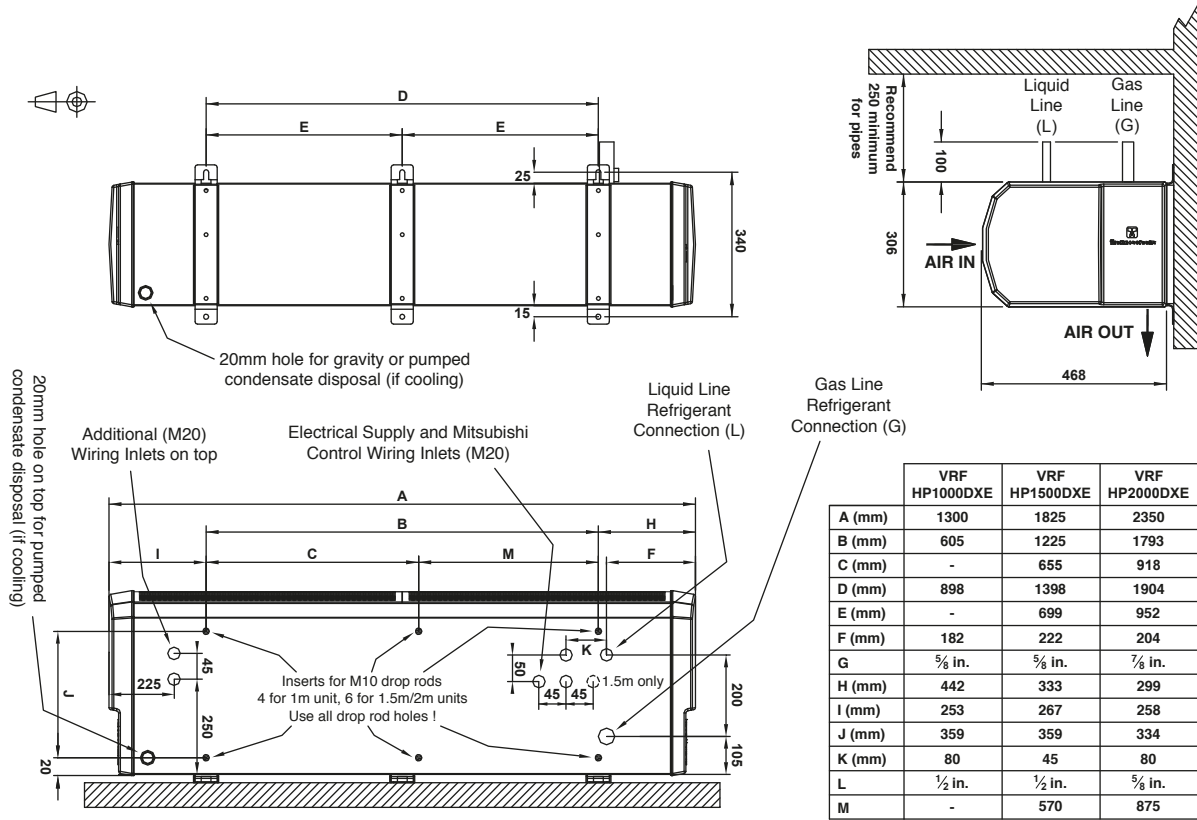

Recessed

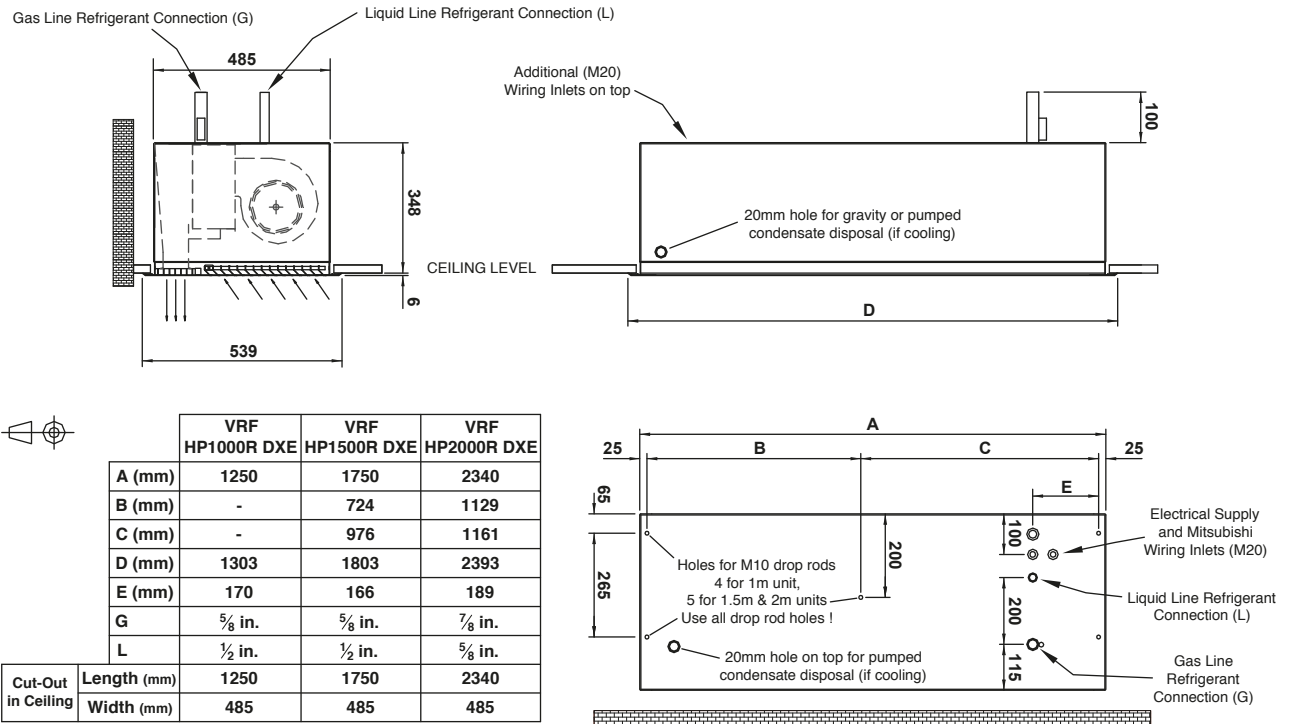

CONTROL OPTIONS

- Mr Slim units can be controlled using energy saving Weather Compensation Control or Discharge Air Temperature Control with PAR-W21 MAA remote controller



**PAR-W21 MAA
Remote Controller**

- Alternatively Mr Slim units can be controlled using Inlet Air Control or Room Temperature Control with PAR-30 MAA remote controller



**PAR-30 MAA
Remote Controller**

- Door Switch to change fan speeds, Door open - High; Door shut - Low (industry standard fan speed control) - Mr Slim and VRF
- 3 - speed Fan switch supplied with the unit for users to select High/Medium or Low speeds - Mr Slim
- Variable heat output
- Defrost mode signal
- City Multi can be used with PAR-30 MAA or PAR-27 MEA
- On/Off facility (Mr Slim and VRF)
- Mode change - Heating, Fan and Cooling (VRF & Mr Slim)
- Error Signal
- Fan speed switching from PAR-30 MAA or PAR-27 MEA with City Multi unit

ACCESSORIES

Standard Equipment Supplied With All Units

All heat pump air curtains are supplied with the following:

- Wall brackets and fixing bolts
- End caps
- Blocked filter indicator
- Grille supplied with recessed unit

Thermoscreens Blocked Filter Indicator

Air curtains are fitted with a blocked filter indicator. It is located at the left-hand end of the outlet grille (within the grille on the recessed air curtain) and signals when the air curtain inlet grille/filters should be vacuum cleaned or the air curtain requires servicing.

Recessed Grille with Filter

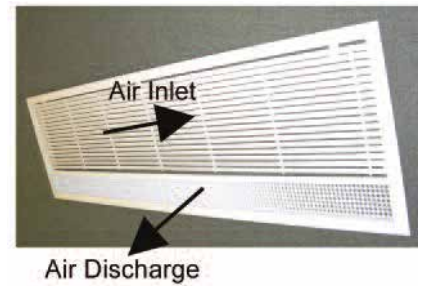

Controllers

Mr Slim Air Curtains



PAR-W21 MAA
For Weather Compensation Control or Discharge Air Temperature Control



PAR-30 MAA
For Inlet Air Control or Room Temperature Control



Remote 3-Speed Fan Switch or Door Switch
To change fan speeds (Door Open - High Speed, Door Closed - Low Speed)

City Multi Air Curtains



PAR-27 MEA



PAR-30 MAA

Thermoscreens



Thermoscreens Limited, St. Mary's Road, Nuneaton, Warwickshire CV11 5AU

Telephone: +44 (0) 2476 384 646 Fax: +44 (0) 2476 388 578

E-mail: sales@thermoscreens.com

Web site: www.thermoscreens.com

