



JET 3, 4.5 & 6 Over Door Heaters.

Installation, Operation and Maintenance Instructions

PLEASE READ THESE INSTRUCTIONS CAREFULLY BEFORE INSTALLATION AND RETAIN FOR FUTURE REFERENCE

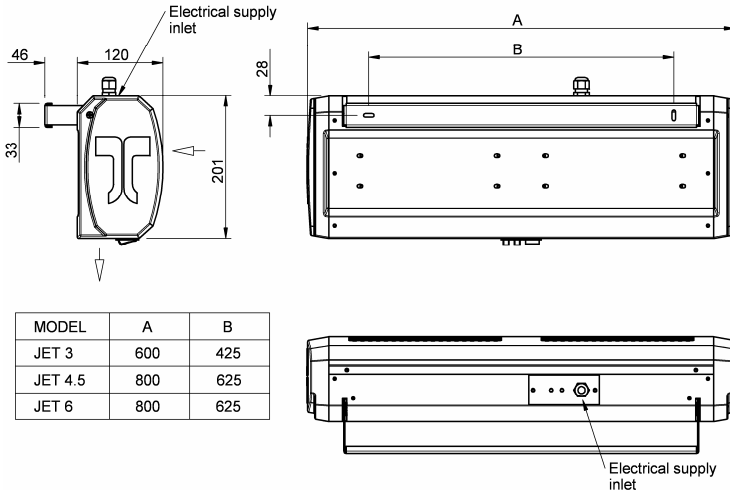

Figure 1: Jet Range General Assembly Drawing

CONTENTS

Remove from carton and check contents include:

- Thermoscreens Jet heater unit
- Mounting bracket
- Cable gland (supplied loose)

For warranty purposes please retain your receipt as proof of purchase.

INSTALLATION

The Jet heater is designed for surface mounting horizontally above a door opening at a height of 1.8m minimum to 2.3m maximum (from floor level to the underside of the appliance). Multiple Jet heaters mounted side by side may be used for wider doorways. The heater must be mounted internally within a building and can be either wall or ceiling mounted.

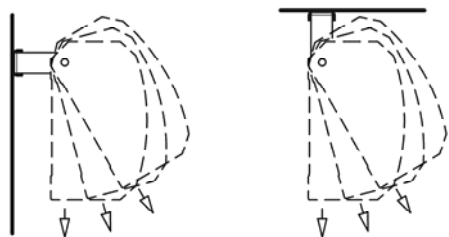

Figure 2: Wall or Ceiling Mounting Options

Before fitting heater obtain suitable screws and wall plugs, taking into account wall or ceiling type and unit weight (see Table 1). The heater must not be located immediately below a socket outlet. Do not cover or obstruct the air inlet or outlet grilles as this can cause overheating and may cause a risk of fire. Do not install heater in environments containing flammable or explosive material.

Using the mounting bracket as a template determine optimum location for the heater, place bracket on the wall or ceiling and mark position of the two fixing holes (refer to 'B' in Figure 1). Drill wall or ceiling accordingly and securely fix mounting bracket into position.

Model	Electrical Input (W)	Weight (kg)	Heat Output (kW)
JET 3	3030	4.5	3.0/1.5
JET 4.5	4540	5.5	4.5/2.25
JET 6	6055	5.5	6.0/3.0

Table 1: Jet Over Door Heater Range

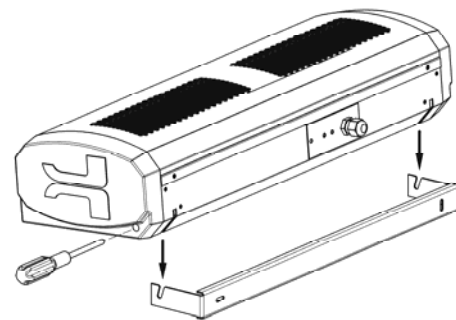

Figure 3: Mounting Bracket Alignment

Align and position mounting bracket into the two slots on the rear plate of the heater (refer to Figure 3).

Ensure the serrated washer, at each end of the heater, is positioned between the mounting bracket and the internal hanging bracket (see Figure 4). Tilt and point heater into the preferred direction and firmly tighten both fixing screws. Using a Pozi No. 2 screwdriver the fixing screws are tightened via access hole in each end cap.

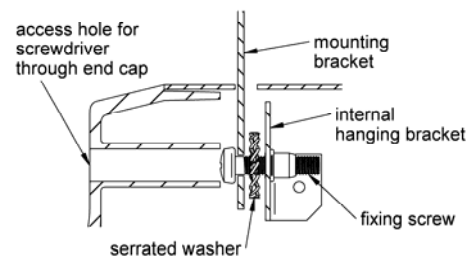

Figure 4: Cross Sectional View of Mounting Bracket

ELECTRICAL CONNECTION

All electrical wiring and connections must be carried out by a competent qualified electrician in accordance with the latest edition of the IEE wiring regulations and/or local statutory regulations.

Ensure that the supply cables, circuit breakers and other electrical installation equipment are correctly sized for the heater being installed, see Table 1. For each heater a single phase local isolator with a contact separation on both poles of at least 3mm must be fitted to the supply wiring (the isolator must be fitted within an accessible position). The heater should be connected to a 230V AC 50Hz electrical supply and must be earthed. Use 3-core round flexible mains cable type 3183Y for the final connection to the heater from the local isolator.

JET 3	15A 1.5mm ²
JET 4.5	20A 2.5mm ²
JET 6	32A 4.0mm ²

Remove two M4 x 12mm pan head Pozi screws at top of the heater and release the power connector plate. Fit cable gland to power connector plate. Insert electrical supply cable via cable gland (see Figure 5) and tighten gland around cable.

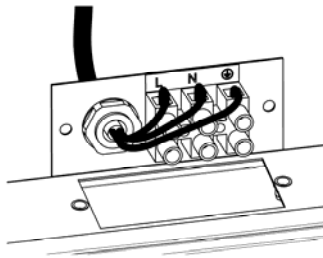

Figure 5: Electrical Connection

Connect each of the cables as follows:-

- Live brown cable to terminal marked L
- Neutral blue cable to terminal marked N
- Earth green/yellow cable to terminal marked \oplus

Position the electrical supply cables as they come out of the terminal block as shown in Figure 5. Ensure only sufficient cable is pulled through to enable connection to terminal block and to avoid excess cable coming into contact with any moving parts. Carefully insert all cables through the rectangular hole in the top of the heater and refit the power connector plate. Ensure mains supply cable is correctly and sufficiently strained by the plastic cable gland.

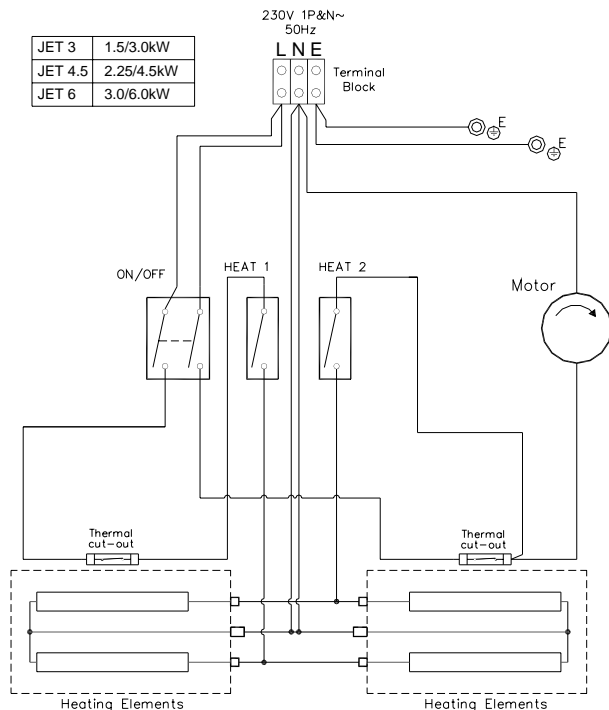

Figure 6: Jet Range Layout Diagram

OPERATION

Control of the heater is achieved by using the three integral switches mounted adjacent to the discharge grille.

Switch	Action
I	Fan on
I + I (Middle)	Fan + half heat
I + I (Middle) + I (End)	Fan + full heat

The heater panels are coated in an easy to peel protective film. Please ensure all the protective film is removed before the air curtain is put into service.

Before leaving site it is important that the over door heater installation and these instructions are "Handed-Over" to the end user or their representative and the operation of it is fully explained and that they understand how it operates.

Note: This appliance is not intended for use by persons (including children) with reduced physical, sensory or mental capabilities, or lack of experience and knowledge, unless they have been given supervision or instruction concerning use of the appliance by a person responsible for their safety. Children should be supervised to ensure that they do not play with the appliance.

THERMAL SAFETY CUT-OUTS

If the heater exceeds normal operating temperature the thermal safety cut-outs will operate and isolate electrical supply to the heating elements. Thermoscreens recommend only competent qualified persons service the heater.

To reset the thermal safety cut-outs disconnect electrical supply to the heater, determine and resolve the cause of the fault. Allow heater sufficient time to cool before restoring supply. If the fault persists arrange for a competent engineer to attend site and investigate.

In order to avoid a hazard due to inadvertent resetting of the thermal cut-out, this appliance must not be supplied through an external switching device, such as a timer, or connected to a circuit that is regularly switched on and off by the utility.

SERVICE & MAINTENANCE

Always disconnect and isolate the mains electricity supply before installing, maintaining or repairing this equipment. All maintenance/repairs should only be carried out by a competent electrician or Thermoscreens appointed technician. To ensure the heater operates efficiently the air inlet and outlet grilles, fan impellers, housings and motors must be kept free of dust and debris. Regularly vacuum and clean any build-up of dirt and debris within the heater (please note that the motor is permanently lubricated and require no additional lubrication). Once the heater has been cleaned check all electrical connections within the unit ensuring terminals are tight and that crimped connections have not become loose. If the outer casing requires cleaning this should be carefully done using a warm soft cloth. Do not use solvents or abrasive materials.

Reconnect the electrical supply and fully function test the heater to ensure correct operation.

WARRANTY

If any problems are encountered, please contact your installer or supplier. Failing this please contact the Thermoscreens warranty department. All units are covered by a one year warranty. Subject to availability we undertake to repair or exchange this product.

Care has been taken in compiling these instructions to ensure they are correct, although Thermoscreens disclaims all liability for damage resulting from any inaccuracies and/or deficiencies in this documentation. Thermoscreens retain the right to change the specifications stated in these instructions.